

Arctica Millwork

Presentation is Everything™

PAY STATION - Example

Item #: _____

Project: _____

Date: _____

To be built to Customer Specifications.

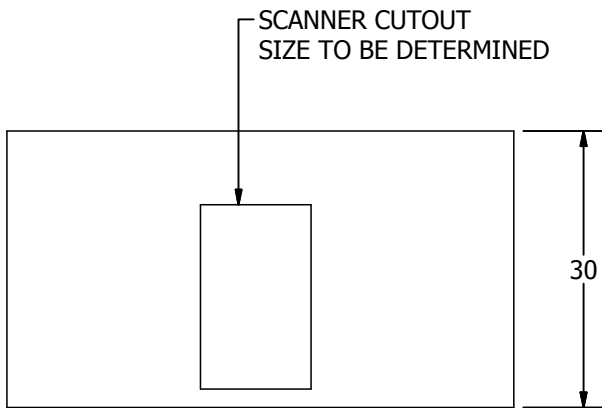

Retracting bag
drawer, on
heavy duty
full ext.
drawer slides

Locking cash drawer
Recommended
(Optional)

1" x 1" Alum.
corner guards
(Optional)

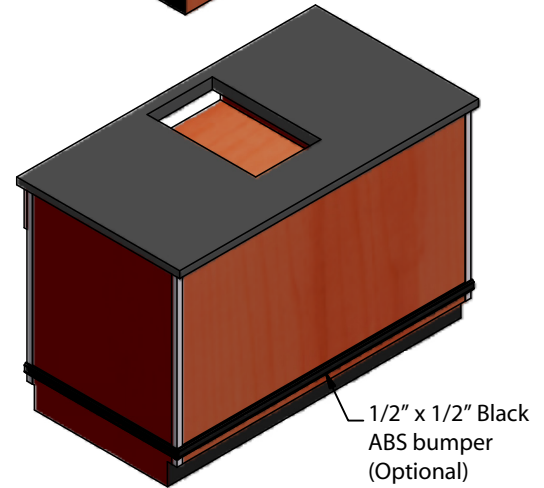
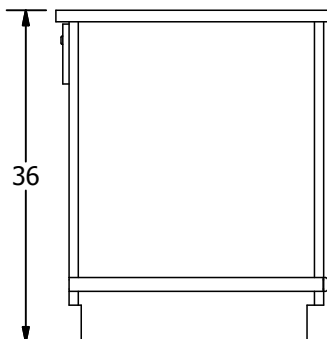
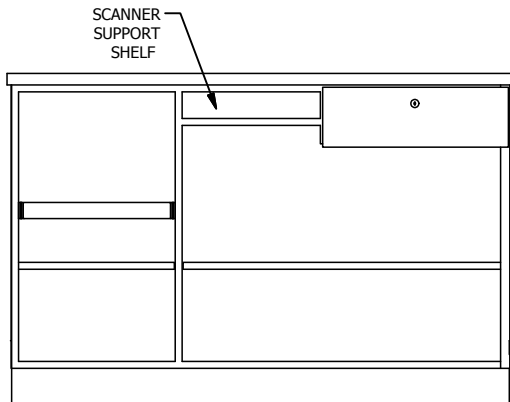

Standard Specifications:

- ☒ Cabinet Construction - White Melamine
- ☒ Exterior - Customer Specification
- ☒ Counter Top - Plastic Laminate

Options:

- ☒ Solid Surface Counter Top

1.800.839.5536

www.arctica.ca



ARCTICA
Millwork
CUSTOM DISPLAY SYSTEMS